

SUBMERSIBLE MAGNETIC DRIVE PUMP

# SUBMERSIBLE

YD-5002GWN

INSTRUCTION MANUAL  
Version: 20110510 (for U.S.A)

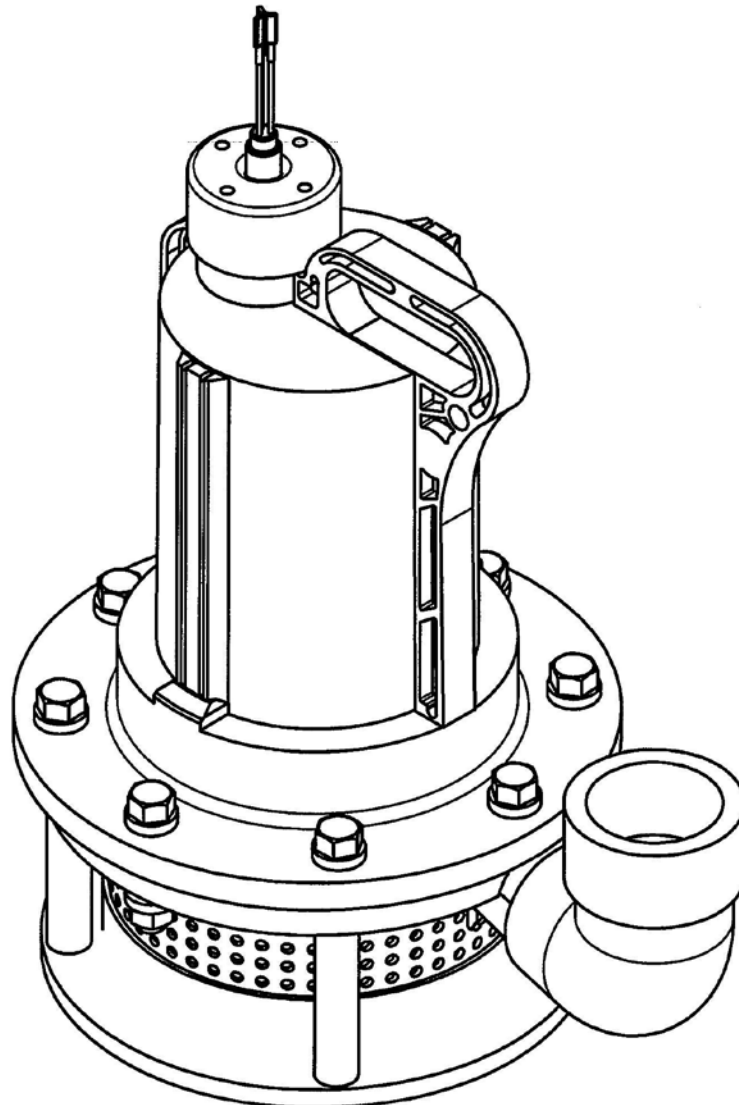

# PREFACE

Thank you very much for purchasing World Chemical's improved magnetic drive pump "Submersible."  
To effectively use SUBMERSIBLE for an extended period of time, it is necessary for the user to properly operate and maintain the pump in accordance with the instruction manual.



## TABEL OF CONTENTS

PREFACE.....	1
TABEL OF CONTENTS.....	1
SAFETY PRECAUTION (To be observed at all times) .....	2
WARNING .....	2
CAUTION .....	3
MODEL DESIGNATION.....	5
SPECIFICATION .....	5
OUTLINE DIMENSION .....	6
PRECAUTIONS IN HANDLING SUBMERSIBLE.....	7
SERVICE LIQUID TEMPERATURE FOR SUBMERSIBLE.....	7
MINIMUM LIQUID LEVEL DURING OPERATION.....	8
MODEL DESIGNATION.....	8
EXAMPLES OF USE .....	9
OPERATIONAL PRECAUTIONS .....	10
ORDER OF DISASSEMBLY.....	11
ORDER OF ASSEMBLY .....	11
EXPLODED VIEW .....	12
TROUBLESHOOTING.....	13
WARRANTY PERIOD AND COVERAGE .....	14
REPAIR .....	14
CONTACT INFORMATION.....	16



# SAFETY PRECAUTION (To be observed at all times)

The following procedures are intended to protect you from personal injury and/or property damage.

- The following symbols classify the degree of danger and explain the damages that could occur when its contents are ignored or the pump is used improperly.

	<b>Warning:</b> Non-compliance can lead to fatal or serious injury.
	<b>Caution:</b> Non-compliance can lead to some injury and/or property damage.

- Safety rules to be observed are classified and explained under the following symbols.
- (The following are examples of picture displays).

	This symbol <b>cautions people to be careful.</b>
	This symbol signifies that this <b>action must not be taken.</b>
	This symbol indicates that the <b>action must be taken.</b>

## **WARNING**

-  (1) Dangerous liquids, and dangerous surroundings.





When using the pump to move dangerous liquids or when using in surroundings (only explosion prevention specifications) Liable to cause explosions, you must adhere to facility standards determined by law and always conduct daily check-ups to look for and prevent leakage. If the pump is operated under abnormal conditions, such as usage during a liquid leak, it could lead to serious accidents such as explosion or fire and personal injury. Please follow the manufacturer’s instructions for handling liquid agents.

-  (2) Do not use damaged or modified pumps.



Do not use the pump if it has been damaged or modified. World chemical is not responsible for any accident or damage of any kind caused by the user remodeling the pump without first obtaining permission or instruction from World Chemical.







-  (3) Caution when transporting or lifting the pump.

Always use the hoist bolt for pumps that come with them. For pumps without hoist bolts, hoist them carefully while watching the weight balance by using a belt sling. This operation must be performed by qualified personnel and the slings used should have sufficient strength. Do no carry pumps by hand as even the lightest pump weighs more than 18kg (40lbs.), and could cause accidents.

-  (4) Do not inspect or dismantle the pump or the motor with the power on.  
Do not inspect or dismantle the pump or motor with the power turned on. This could lead to personal injuries from electric shock or from getting caught in the rotor. Work should be performed only after verifying that multiple safety precautions have been taken, such as the switch for main power supply is off, the operation switch is off, and the hand switch for the pump is off.
-  (5) Connecting grounding line.  
Using the pump without attaching the ground line from the motor could cause electric shock. The grounding operation must be performed by a qualified person in accordance with electric facilities technical standards and interior wiring regulations.
-  (6) Protecting the power supply cord.  
Stretching, pinching or otherwise damaging the power supply cords or motor lead wires could cause fire or electric shock. Always replace the cover of the terminal box before use.
-  (7) Installing Ground Fault Interrupter (GFI)  
Electric shock might result if the pump is used without attaching ground fault interrupter device. Protect the pump from accidents and damages caused by current overload by always attaching circuit breakers, over-current protection devices and/or other protective devices.
-  (8) Caution when removing pump  
Before removing the pump from piping, close the intake and discharge pipe valves and verifying there are no liquid leaks. Drain all liquid from the pump. Always wear protective gear when performing these operations as direct contact with the fluids could cause injuries.

## CAUTION

-  (1) Unspecified use.  
Do not use the pump for purposes other than those specified on the nameplate. Verify the power specification of motor (phase, voltage and frequency) prior to wiring the motor. Unspecified use could cause personal injuries or damage to the pump and peripheral equipment.
-  (2) Restrictions on persons handling the pump.  
Transportation, installation, wiring, operation, servicing, and inspection should be performed only by an expert who has full knowledge of the handling the pump.

-  (3) Opening package.  
Before opening the package verify that the top side of the package is up. When opening a wooden crate, be careful to avoid injury from nails and silvers when removing the product.
-  (4) Ventilation.  
Do not obstruct ventilation of the motor. This could cause the motor to overheat. If handling toxic or odorous liquids, have the pump situated in a well-ventilated place to prevent poisoning.
-  (5) Repairs and returning the pump.  
In the event of a pump failure, contact World Chemical or your nearest sales agent for repairs. If the pump is to be returned for repairs, decontaminate and clean interior and exterior of the pump before returning.
-  (6) Regarding thermoplastic (resin) parts.  
The pump is made of thermoplastic resin material. Therefore, it could cause injuries if it becomes damaged through impact with other objects. Refrain from having people hit a pump against any objects. Attach piping support to avoid any pipe load stress on the pump.
-  (7) Verifying rotation direction of the motor and starting the pump.  
Verify the direction of rotation when initially starting up the pump. Open the intake and discharge valves first, and check that there is no liquid leakage from the pipe connection. Verify the pipe is emptied of air and the pump is filled with liquid, and then, turn on the switch for a split second to check the direction of rotation. If the rotation reversed, switch two of the three phases in the three phase power supply to change the direction of rotation. Turn off the power supply and confirm that it is safe before switching the two phases.
-  (8) Disposing of scrapped pump.  
When disposing a scrapped pump, thoroughly flush any hazardous materials from the pump and discard as industrial waste in accordance with the law.
-  (9) Leak protection.  
Always take appropriate preventative measure to safeguard against liquid leaks in the event of a pump breakdown or piping.

## MODEL DESIGNATION

MODEL: YD-5002GWN  
 YD-5002GWN-HP (High pressure type, only 60Hz)  
 TYPE: Chemical Submersible Magnetic Drive Pump  
 TRADE NAME: SUBMERSIBLE

## SPECIFICATION

Model	Frequency	Standard specification		Output	Power source	Discharge bore	Weight
		Total head	Capacity				
5002GWN-HP	60Hz	39 ft (11.9m)	26gpm (100L/min)	1.5HP (1.1 Kw)	460 V 60 Hz	2" (50mm)	57 lbs (26kg)

Bore		2" (50mm)		Insulator		H	
Model		5002GWN-HP		Rated output		1.5 HP (1.1kW)	
Frequency		60Hz		Phase		3	
Total head	Maximum	ft (m)	41 (12.5)	Pole		2	
	Standard		39 (11.9)				
Capacity	Maximum	gpm (lpm)	87 (330)	Rated voltage	60Hz	460V	
	Standard		26 (100)				
Others							
Dimension	Outline	in (mm)	14 x 10 (380 x 250)	Starting current	60Hz	23.1A	
	Height		16 (412)				
Weight		lb (kg)	57 (26)	Method of starting		Direct	
Attached cable			4 Insulated Copper Conductors*	Rotating speed	60Hz	3370 RPM	
			16AWG x 32.8ft 1.25 mm x 10m				
Thermal protector			Built-in motor	Liquid temperature (Max)		158°F (70°C)	

\*Insulation Types : White = S (or V) , Red = R (or U), Black = T (or W), Green = Earth

# OUTLINE DIMENSION

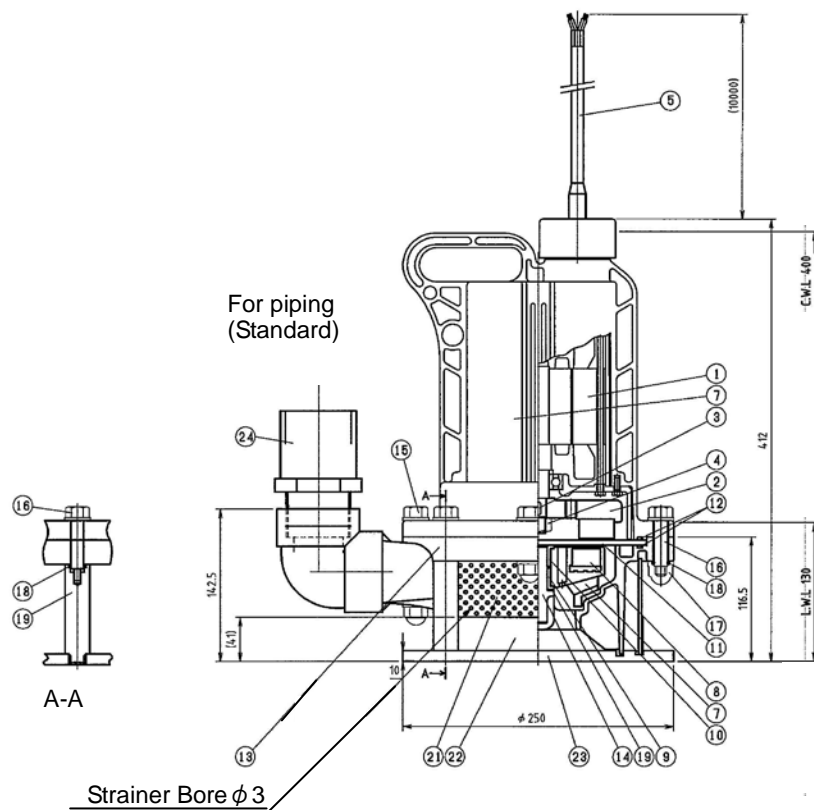

Parts name	Reference
Motor	FC
Motor magnet	Ferrite
Motro magnet key	SS
Motor magnet nut	SS
Cabtyre cable	2PNCT
Motor cover	CFR PP
Impeller	CFR PP
Impeller magnet	Ferrite
Front bearing	PTFE / Ceramic
Rear bearing	PTFE
Separating board	Ceramic
O-ring for separating board	FPM / EPDM
Casing	CFR PP
Shaft	SiC

No.	Parts name	Reference
15	Set bolt 92	CFR PP
16	Set bolt 52	CFR PP
17	Nut for set bolt	CFR PP
18	O-ring for set bolt	FPM / EPDM
19	Floating washer	PTFE (Only Ceramic bearing)
20	Stud bolt	HT, PVC
21	Strainer	PP
22	Sludge fence	PP
23	Bottom plate	PP
24	50A Valve socket	PVC

## **FEATURES OF SUBMERSIBLE**

SUBMERSIBLE is constructed of Carbon Fiber Reinforced Polypropylene and a corrosion resistant shaft and structurally adopts a magnet drive system that does not require a shaft seal, which remains unaltered by the addition of strong acids and strong alkalis.

1. All wet kit parts are composed of corrosion resistant resin and ceramic.
2. The pump can also handle strong acids and strong alkalis.
3. The magnet drive system does not require a shaft seal and lets the liquid enter the motor.
4. It has a simple construction, no consumables, and easy part(s) replacement.
5. Operation of the pump is as simple as lowering it into a tank. The pump will also operate when suspended.
6. The pump has a handle for carrying and is suitable for emergency use.
7. For the discharge pipe, we have a system that employs flexible hose, as well as a system that employs a fixed piping constructed of polypropylene and heat resistant vinyl chloride.
8. Because a strong ceramic plate is used to isolate the motor from the pump chamber, it is fully reliable in pressure resistance and chemical resistance.
9. If abnormal heat is detected, electrically or mechanically, during operation, the auto cut will operate to stop the motor by working the built-in thermal protector.

## **PRECAUTIONS IN HANDLING SUBMERSIBLE**

1. In cases of slurry, use ceramic bearing. (Floating washer is consumable part.)
2. In case of high concentrations of sulfuric acid, more than 93%, SUBMERSIBLE cannot be used.
3. Never operate SUBMERSIBLE in air.

## **SERVICE LIQUID TEMPERATURE FOR SUBMERSIBLE**

Maximum: 70°C (158F) Cable material: 2PNCT



# EXAMPLES OF USE

1. Pumping liquid or waste liquid from a deep or narrow pit or tank.
2. Pumping forming liquid.
3. Pumping chemical liquid from sealed tank.
4. Circulation of liquid in a tank
5. Mixing liquid in a tank or a device
6. Transferring on an emergency basis

Pumping from a deep tank

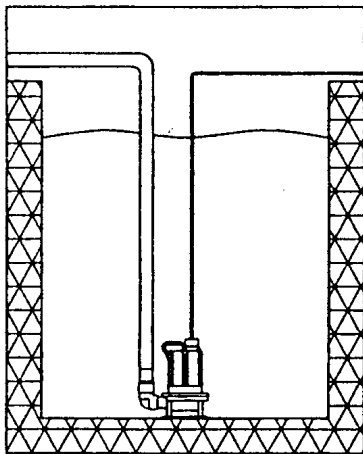

Pumping from a shallow tank that foams easily

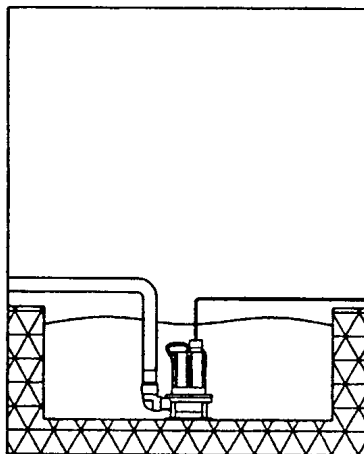

Pumping liquid from a narrow and deep tank

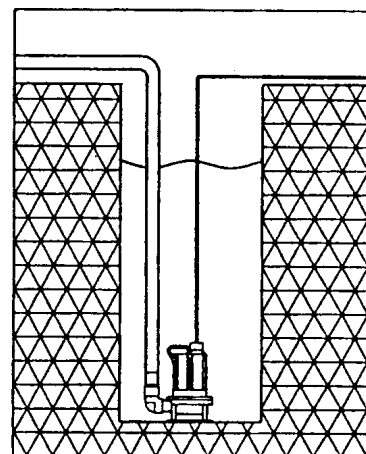

Scrubber system  
(Washing system)

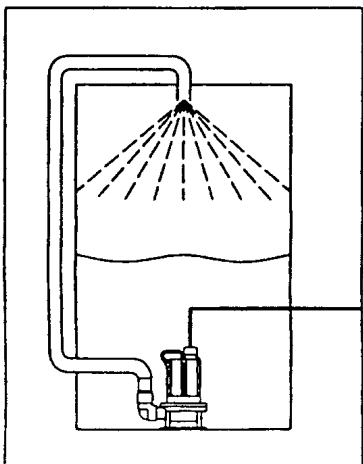

Transferring from a pump truck

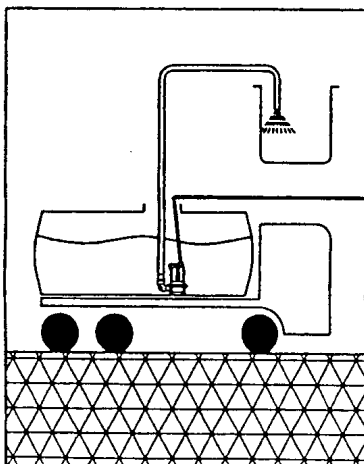

For mixing

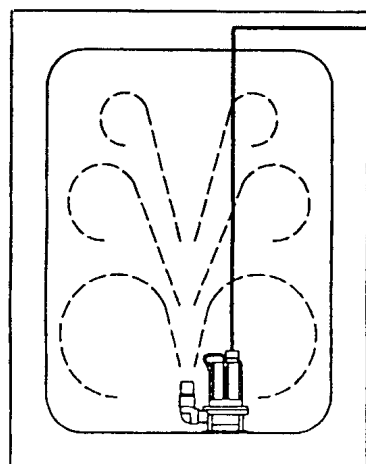

# OPERATIONAL PRECAUTIONS

## 1. Electric wiring

Before starting operation, always check the direction of rotation. If U (red), V (white), W (black), and ground (green) are connected to the U, V, W and earth respectively for power supply, the motor will rotate in a forward direction (clockwise as viewed from the top).

The following is a reference for checking the direction of rotation:

1-(1) In reverse rotation, the discharge output is only 30% of the forward rotation.

1-(2) If the pump is placed in water, rotation will be in a forward direction the moment the switch is turned on.

**Note: If the direction of rotation is counterclockwise, two of the three lines (red, white or black) are switched.**

## 2. Precautions for Electric wiring

2-(1) To prevent electric shock, always connect a green ground wire to the earth plate or bar before connecting the cable.

2-(2) When inching the pump to test the direction of rotation, never operate the motor in air. The pump may otherwise deform from the heat and incur damage.

2-(3) Always use a circuit breaker to prevent any problems in emergency cases.

**Note: To prevent electrical shock or fire, the user is obligated to provide a leak breaker according to the industrial safety and Health Regulation and Electric Equipment Technical Standard.**

## 3. Voltage during operation

When voltage is low, the current will increase and the stator temperature will rise to operate the thermal protector to protect the motor. Since low voltage causes poor performance, use the pump at a voltage within the specified range.

**Note: The service voltage for this pump is within  $\pm 10\%$  of the rated voltage.**

## 4. Thermal protector (Protection Instrument)

When the temperature of the motor coil is near burning temperature due to electrical or mechanical causes, the thermal protector (which prevents burns) will automatically operate within the motor, cut off the electrical circuit and stop the motor. At this time, carefully inspect the source of the thermal protector and make any appropriate changes before resuming operation.

**Note: Always cut off the power supply before inspection. The thermal protector will automatically reset itself.**

## ORDER OF DISASSEMBLY

Please see *EXPLODED VIEW*.

1. First remove the four set bolts (16), which fasten the casing (13) from the stud bolts (21).
2. Remove the bottom board (23) with the stand bolts (20), and the strainer (21).
3. After removing the set bolts (15) (16), place the entire pump horizontally and pull the casing (13) to separate. An impeller (2) has been secured to the motor cover (1) through the separating board.
4. Remove o-ring for separating board (12) and move the impeller attached to the driving side magnet (2) outwards.

\* Do not disassemble the motor (cable included). Please contact a distributor in your area or customer service at the time of an overhaul of the motor.

## ORDER OF ASSEMBLY

1. Place the o-ring (12) on the groove in the motor cover (1) and gently mount the separating board (11).
2. Slide the impeller (7) from the edge of the separating board (12) to the center. Be sure not to slide the impeller quickly so that the impeller (7) that is pulled toward the drive magnet (2) by magnetic force will not damage the separating board (11).
3. To set an installation position of the casing (13), insert the pump shaft that is part of the casing (13) into the bearing of the impeller (7) and tighten the casing with the bolts.
4. Attach the stand bolts to the bottom board (23). Place the strainer (21) on the bottom board, and tighten it with set bolts (16).

\* Tightening torque for set bolt (15) (16) is 8N·m.

# EXPLODED VIEW

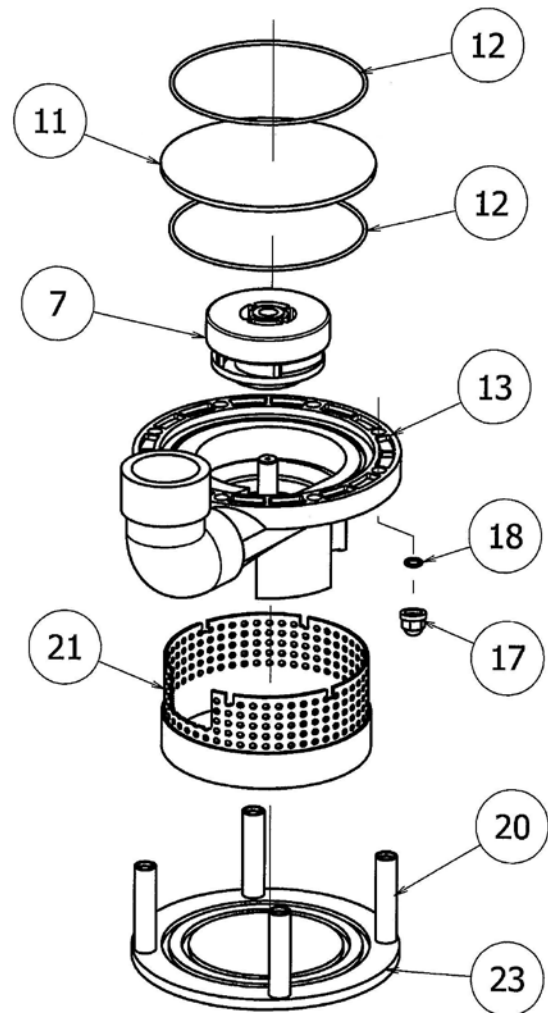
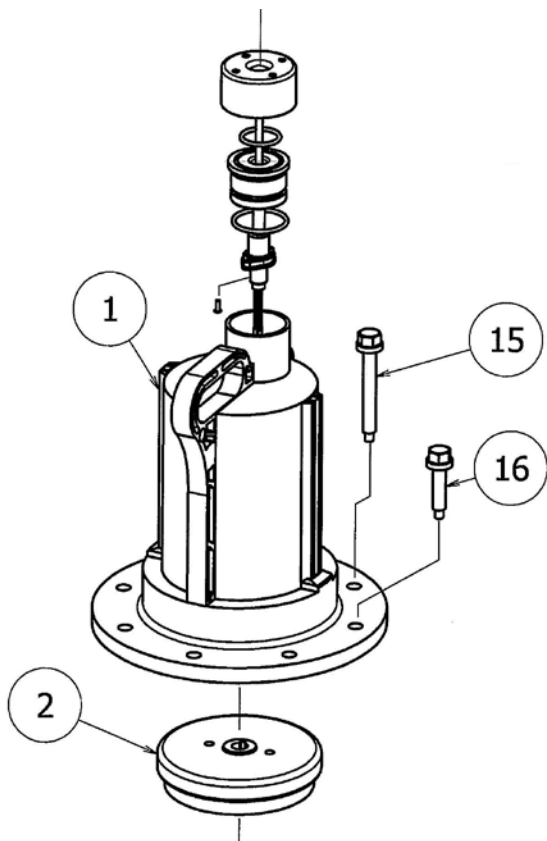

# TROUBLESHOOTING

## 1. Unable to pump or insufficient pumping

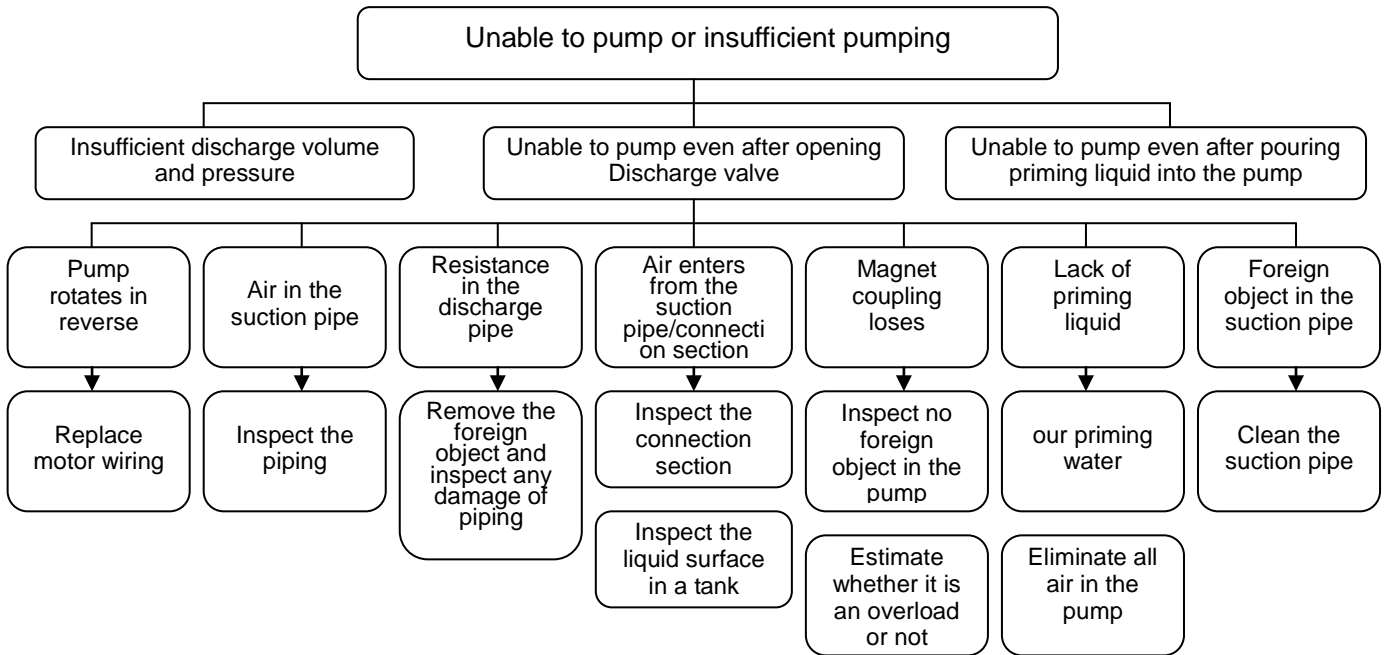

## 2. Motor overheats

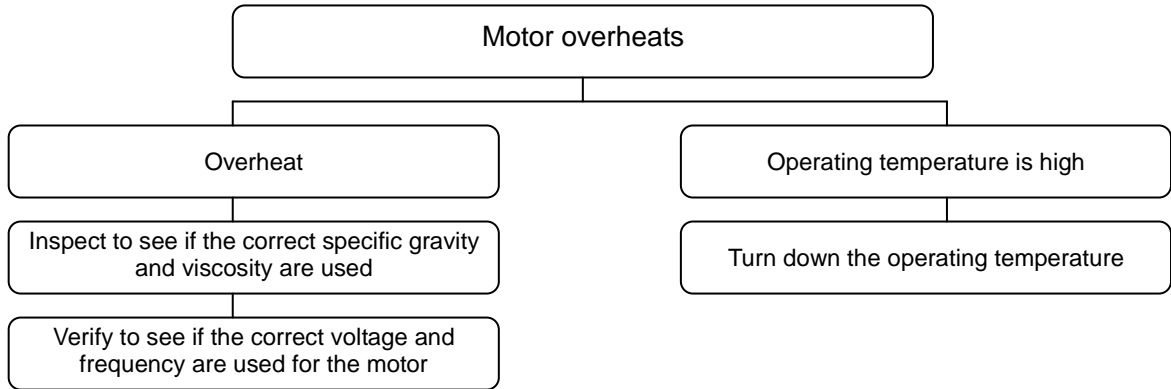

## 3. Pump vibrates

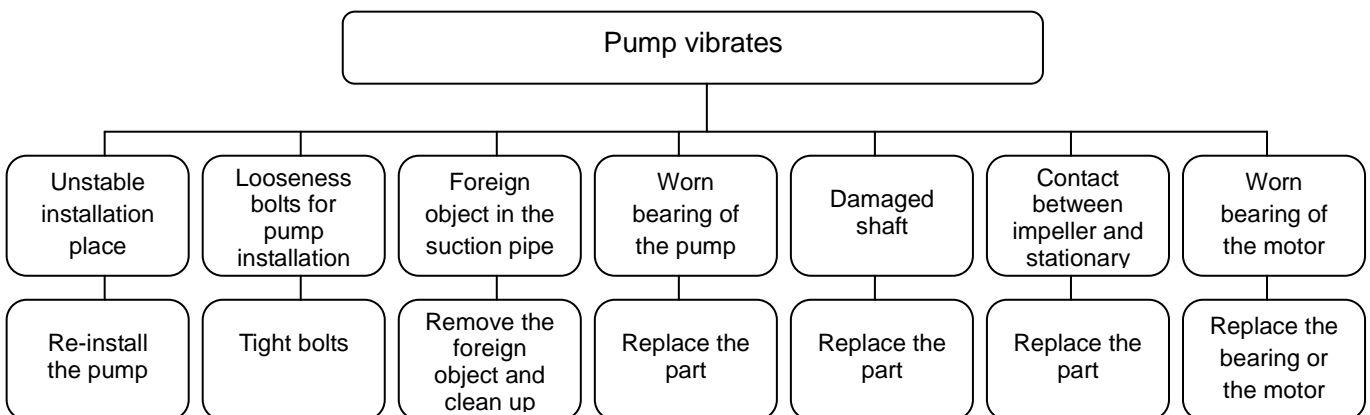

## WARRANTY PERIOD AND COVERAGE

1. The warranty period is one year from the date of delivery.
2. During the warranty period, if the unit fails or becomes damaged in a normal operating condition due to manufacturing defect(s), the failure or damaged part(s) will be repaired free of charge.
3. There will be a service charge for repairing the following failure(s) or damage(s) and for the replacement of worn part(s):
  - a. Any failure or damage occurring after the warranty period.
  - b. Any failure or damage due to improper use or safekeeping.
  - c. Any failure or damage due to the use of part(s) manufactured by other or the use of unauthorized parts.
  - d. Any failure or damage from repair or modification performed by an unauthorized agent.
  - e. Any failure or damage as result of natural disaster or force majeure.
4. The manufacturer is not responsible for any failure or damage of a product operated according to the specification or material designated by the customer.
5. The warranty does not cover irregularities or failures caused by chemical or hydrodynamic corrosion, or the property of the liquid pumped. The material chosen at the time of purchase is strictly a recommendation; the chemical resistance of the material is not guaranteed.
6. Any disputes over the cause of a failure or damage shall be resolved through discussion between the customer and the manufacturer.
7. Travel expenses for non-warranted repair service to a remote location will be the responsibility of the customer.
8. Damages and costs of damages incurred as a result of pump failure during operation is not covered under the warranty.

## REPAIR

Attention: For repair, please contact the local supplier of our products. When returning a pump, please clean the wet kit parts thoroughly with water and pack properly.

If any irregularity is detected during operation, immediately stop the pump and inspect it.

(See the section *TROUBLESHOOTING*.)

- a. To request a repair service, please contact your local supplier or the manufacturer's service department.
- b. Before requesting repair service, please carefully read the instruction manual again and recheck the pump.

c. When requesting repair service, please provide the following information:

- Model name and serial number
- How long the unit has been used and its condition
- Damaged section and its condition
- Liquid pumped (name of liquid, specific gravity, liquid temperature, presence of slurry)

When returning a failed pump, please ensure to thoroughly wash the inside of the pump to prevent the danger of liquid leakage from the pump during transit.

When ordering replacement or spare parts, please provide the part names, part numbers and material listed in the table in the section *OUTLINE DIMENSION*.

MODEL	YD-
SERIAL NO.	
DISTRIBUTOR	
DATE OF PURCHASE	

# CONTACT INFORMATION

## Head Office

---



3<sup>rd</sup> Floor, ANTEX24, 1-1-14 Taito, Taito-ku,  
Tokyo 110-0016 Japan

TEL: 03-5818-5134 FAX: 03-5818-5131

E-mail: [overseas@wcc.co.jp](mailto:overseas@wcc.co.jp)

Website: <http://www.wcc.co.jp>

## North / South America / Canada

---



30 Hughes, Suite 203, Irvine, CA92618 U.S.A.

TEL: 949-462-0900 FAX: 949-462-0999

E-mail: [wca@worldchemicalusa.com](mailto:wca@worldchemicalusa.com)

Website: <http://www.worldchemicalusa.com>

Distributed by